

# TRK 600X800 RACK KABİN MONTAJ ŞEMASI

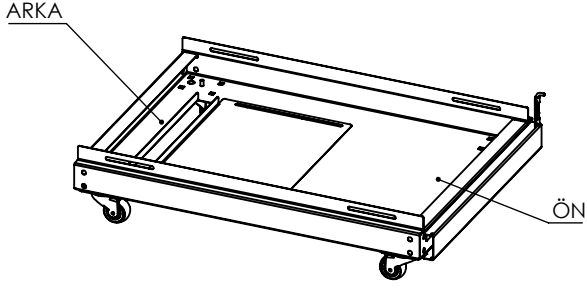

ALT BAZAYI DÜZ BİR ALANA YERLEŞTİRİNİZ

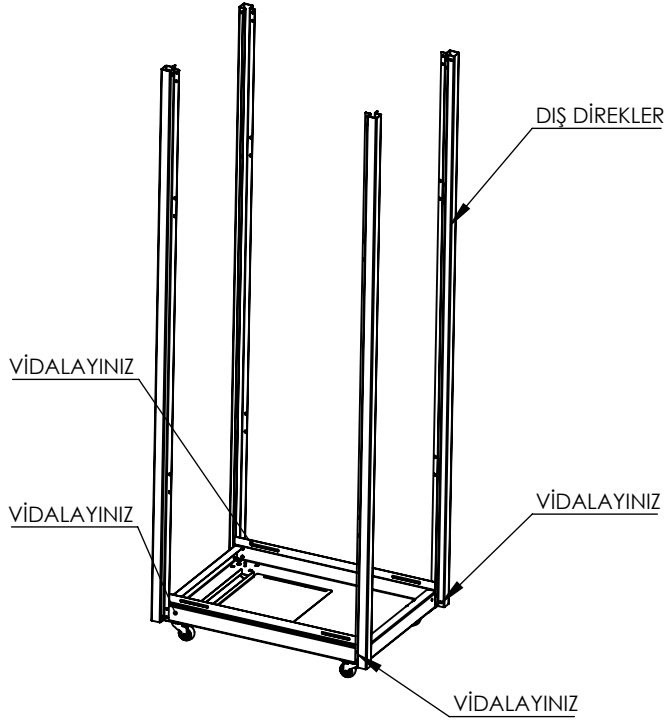

DIŞ DİREKLERİ YERLEŞTİRİP VİDALAYINIZ

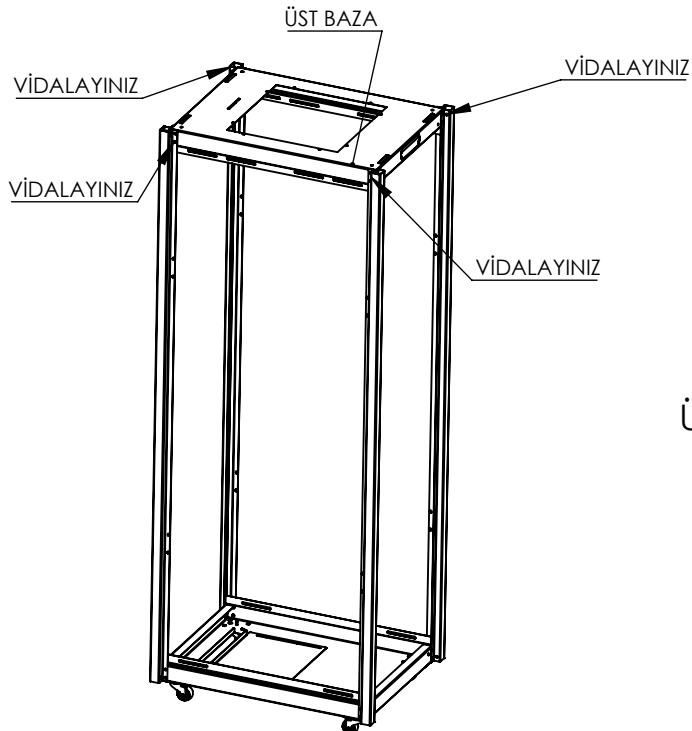

ÜST BAZAYI YERİNE YERLEŞTİRİP VİDALAYINIZ

#### 4. ADIM

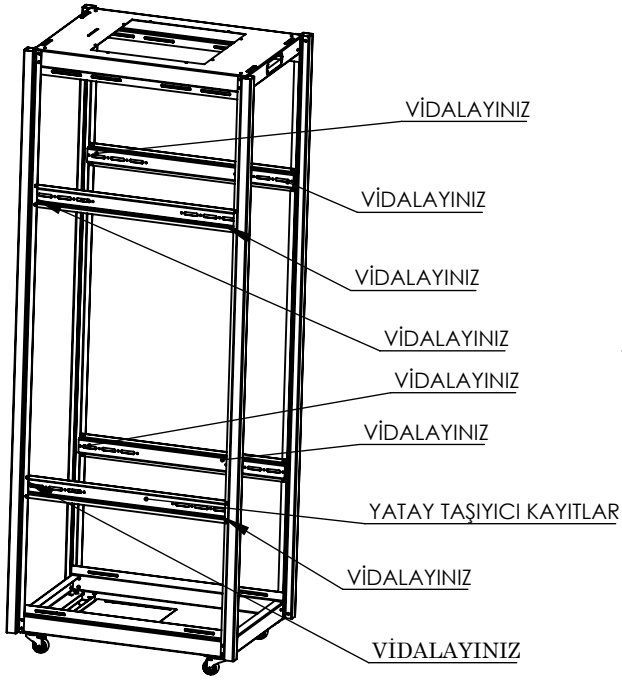

YATAY TAŞIYICI KAYITLARI VİDALAYINIZ

#### 5. ADIM

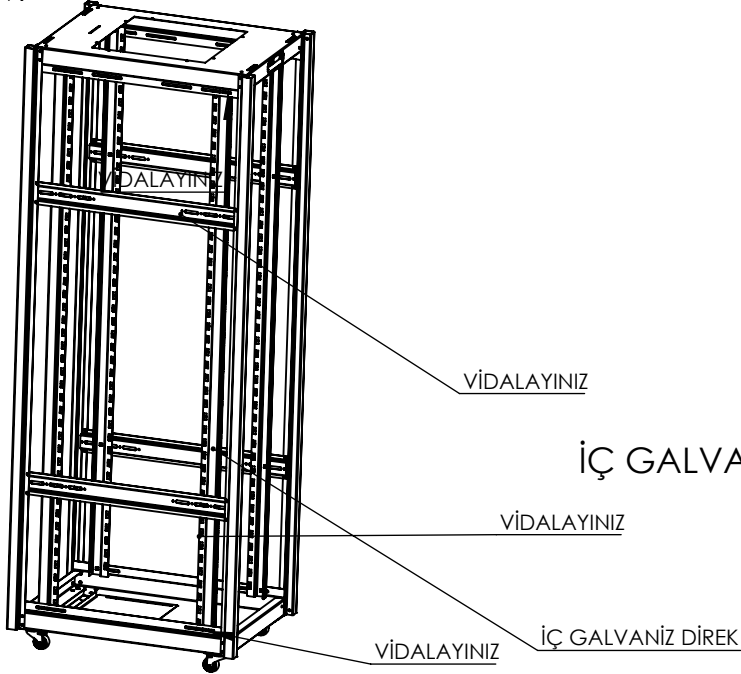

İÇ GALVANİZ DİREKLERİ VİDALAYINIZ

#### 6. ADIM

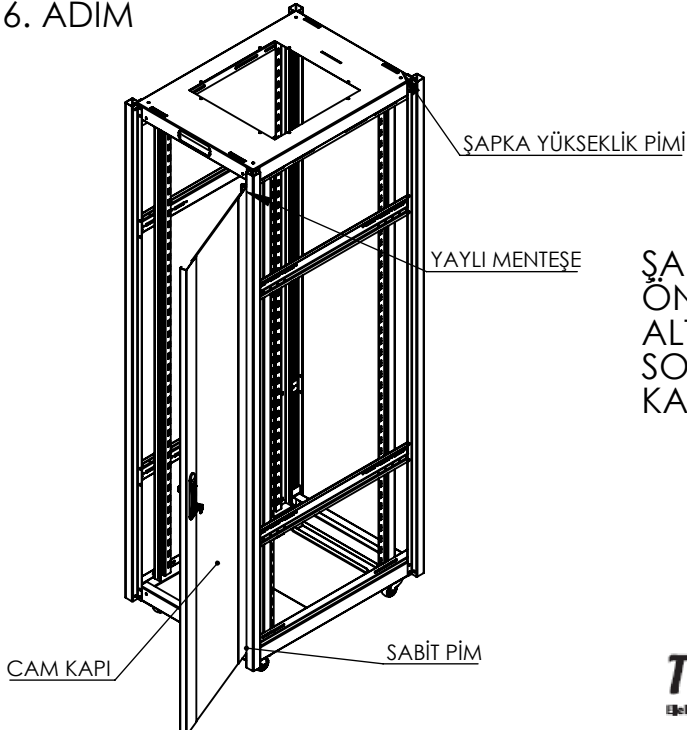

ŞAPKA YÜKSEKLİK PİMLERİNİ TAKTIKTAN SONRA  
ÖN CAM KAPININ ALT KISMINDA BULUNAN YUVAYI  
ALT BAZA ÜZERİNDEKİ SABİT PİME YERLEŞTİRİN DAHA  
SONRASINDA KAPI ÜST KISMINDAKİ YAYLI MENTEŞEDEN  
KAPIYI SABİTLEYİNİZ.

## 7. ADIM

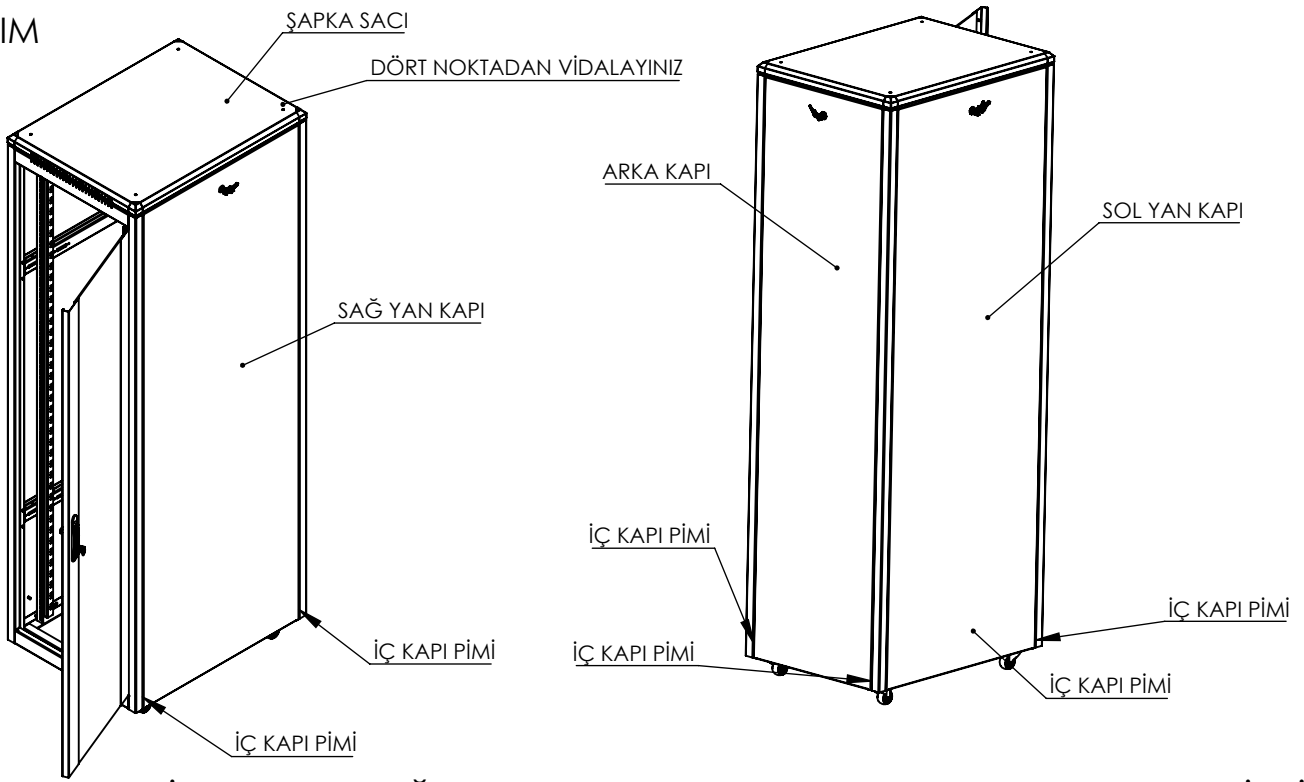

ŞAPKA SACINI VİDALAYINIZ.SAĞ-SOL VE ARKA KAPIYI ALT KISIMDA BULUNAN SABİT PİMLERE YELEŞTİRİP ÜST KISIMDA BULUNAN KİLİT ANAHTARINI ÇEVİREREK KİLİTLEYİNİZ  
BÖYLELİKLER RACK KABİN MONTAJI TAMAMLANMIŞ OLUR

