

800x1000 42 U 4 DOOR OPENING RACK CABIN ASSEMBLY DIAGRAM

STEP 1

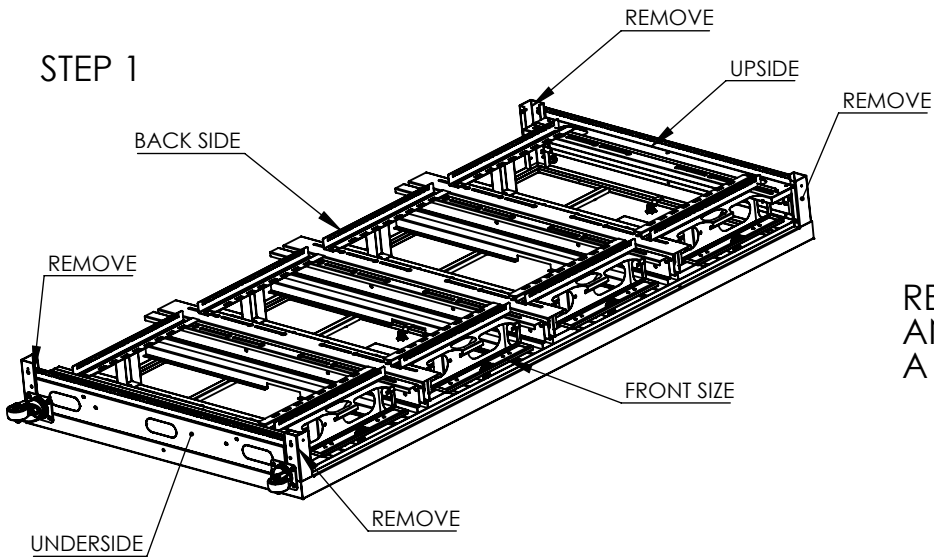

REMOVE THE CONNECTION PLATES
AND PLACE THE RIGHT CHASSIS ON
A FLAT FLOOR

STEP 2

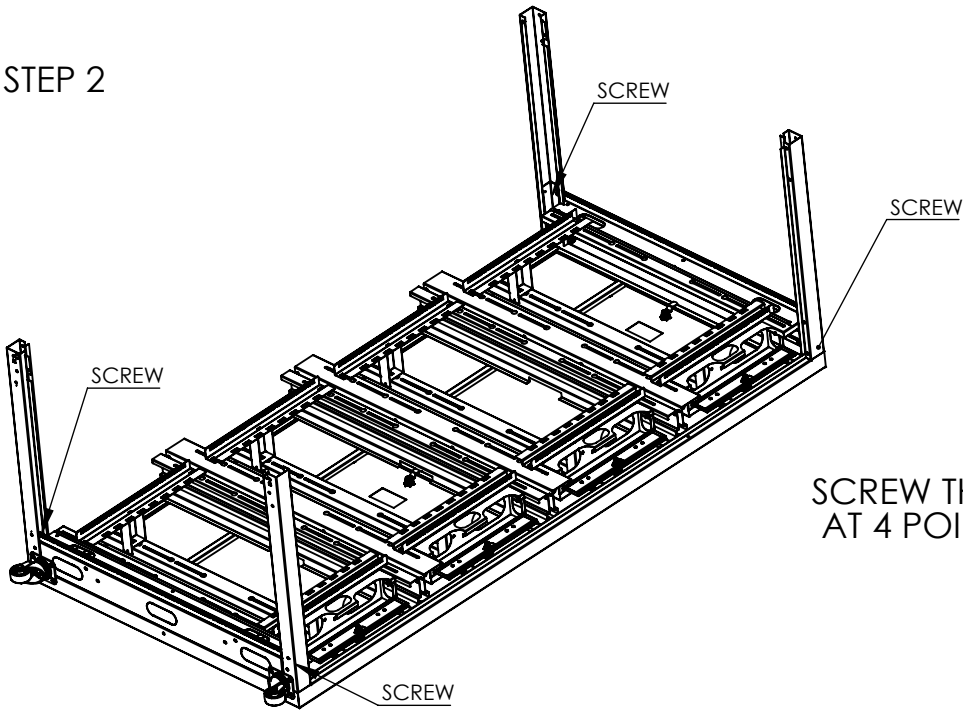

SCREW THE HORIZONTAL RECORDS
AT 4 POINTS

STEP 3

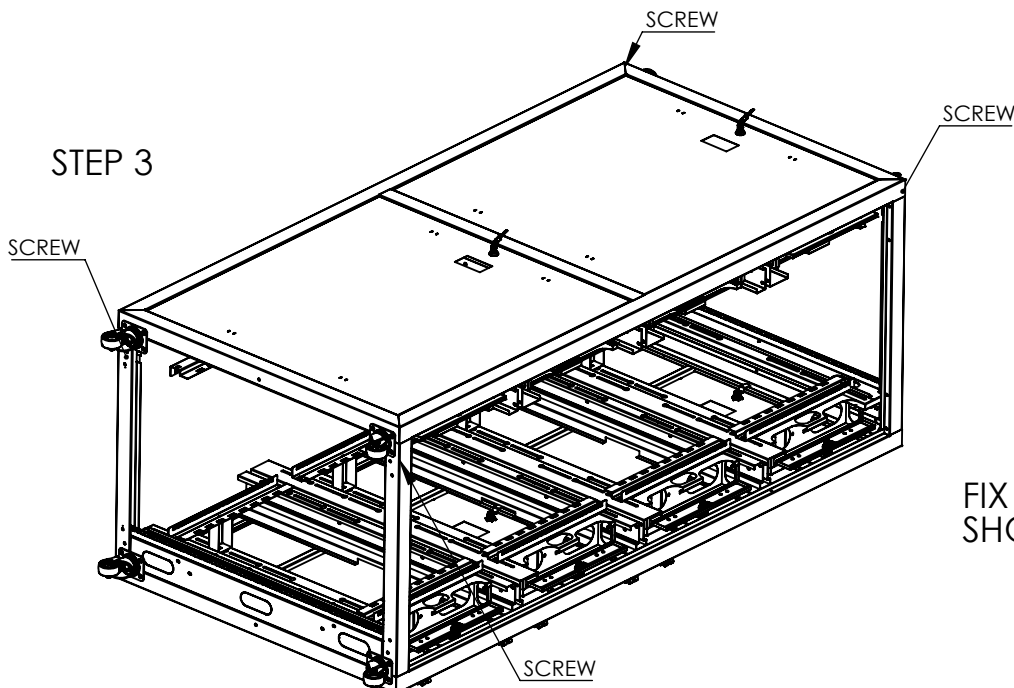

FIX IT BY SCREW AT THE 4 POINTS
SHOWN ON THE LEFT FRAME

STEP 4

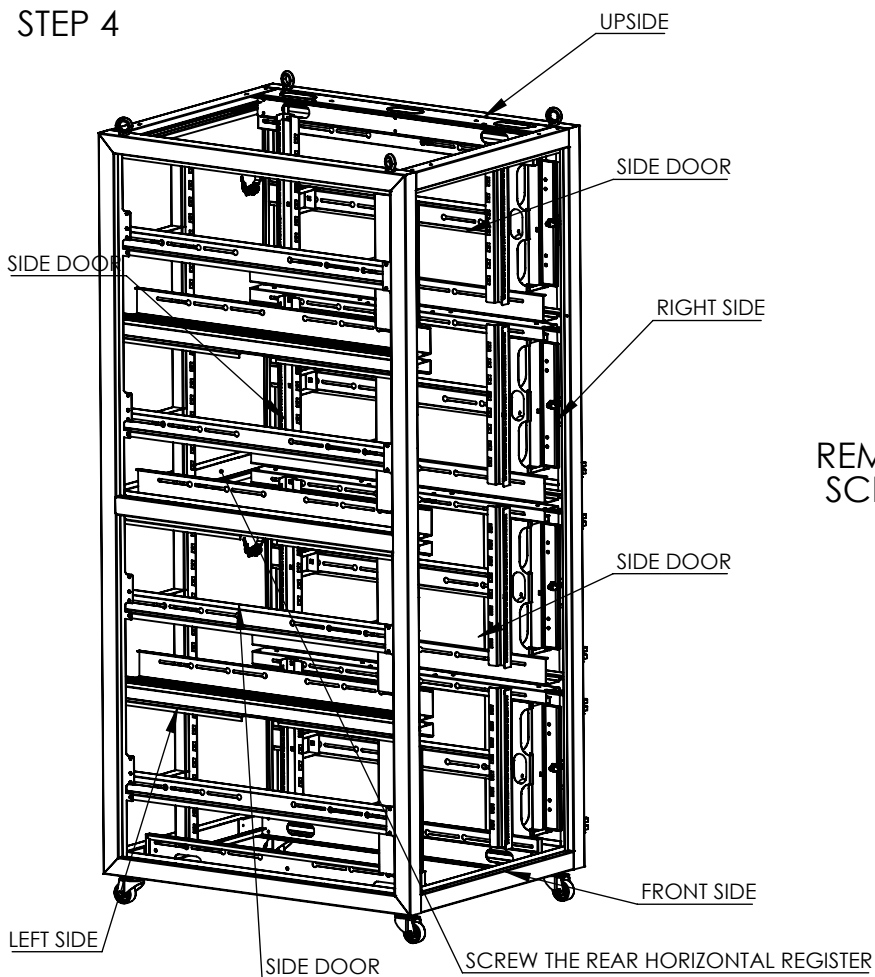

REMOVE THE SIDE DOORS AFTER SCREWING THE REAR HORIZONTAL RELEASE

STEP 5

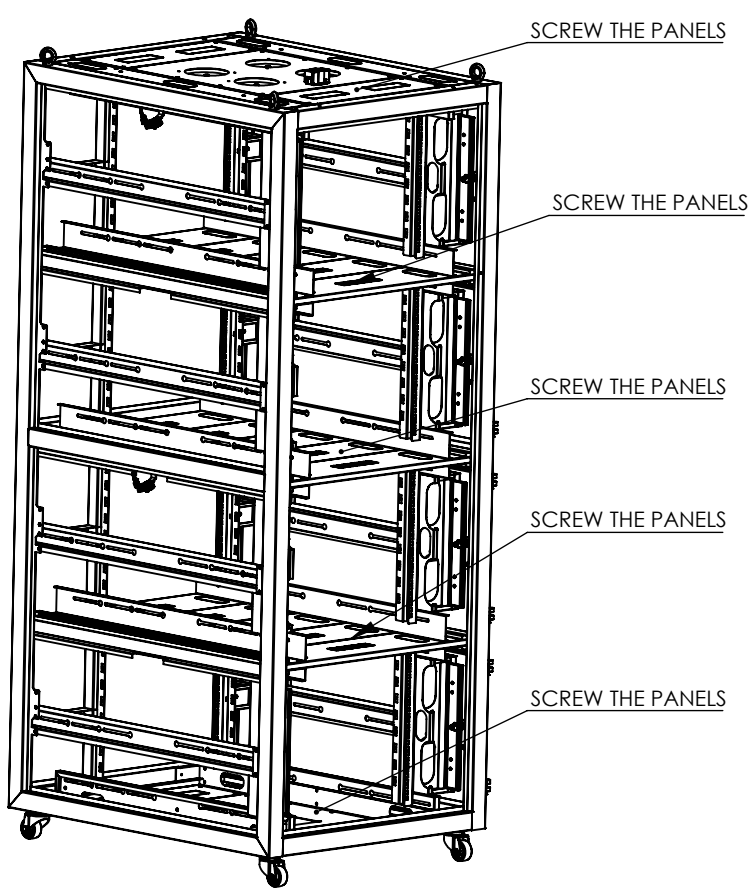

SCREW ALL FLOOR PARTS AND VENTILATION FAN PANELS

STEP 6

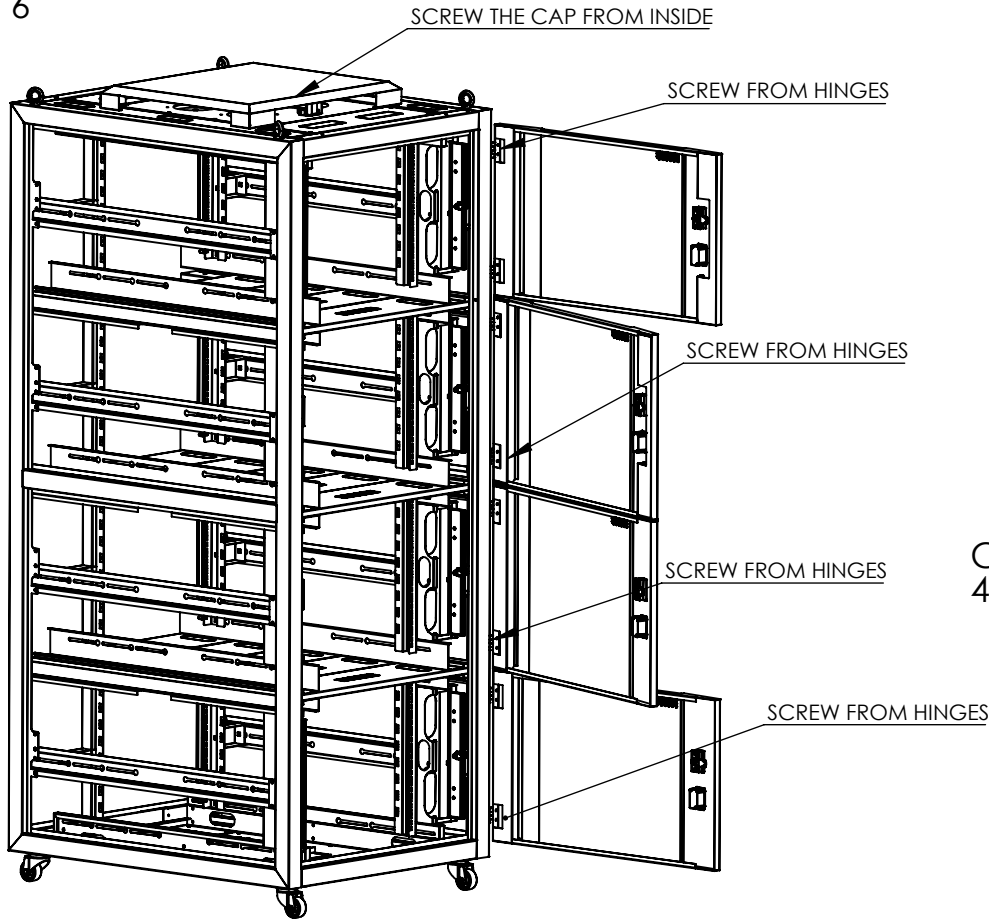

STEP 7

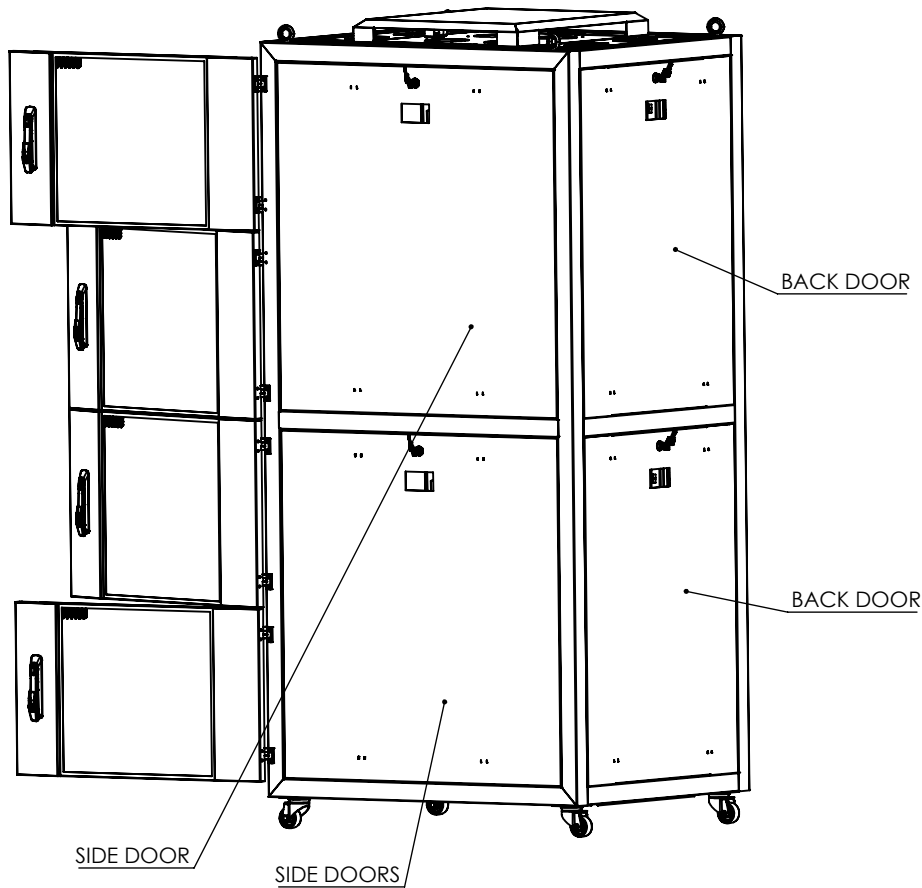

REPLACE ALL SIDE AND REAR DOORS AND FIX IT WITH THE WRENCH

THUS, THE ENTIRE ASSEMBLY PROCESS IS FINISHED