

800X1000X42 U ERK TYPE RACK CABINET ASSEMBLY DIAGRAM

STEP 1

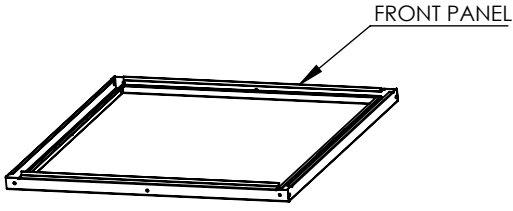

PLACE THE FRONT FRAME ON A SMOOTH FRAME

STEP 2

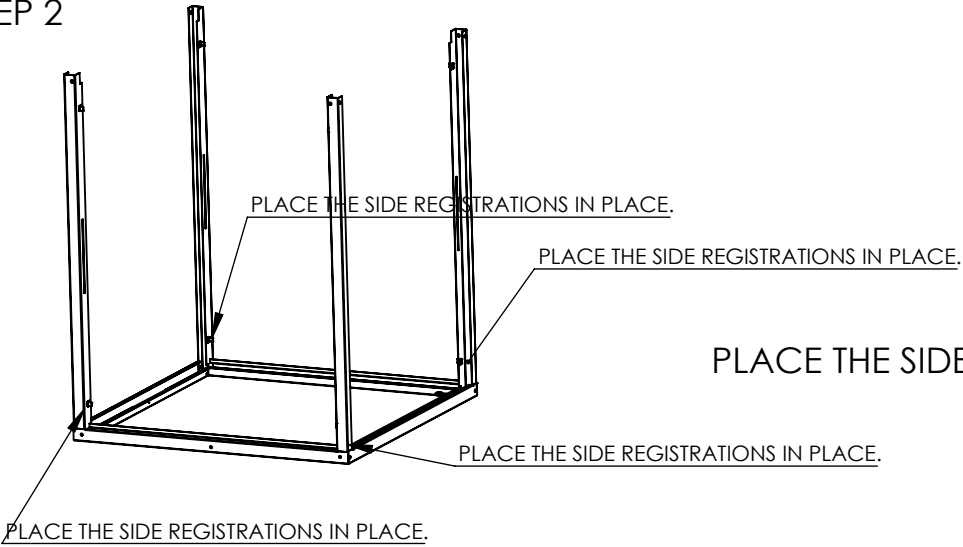

PLACE THE SIDE REGISTRATIONS IN PLACE.

STEP 3

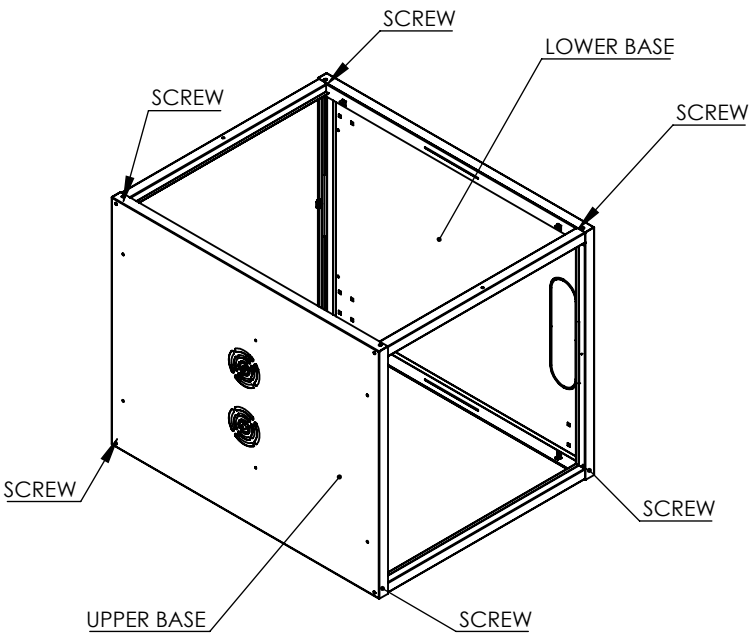

SCREW THE BOTTOM AND UPPER BASE FROM THE SHOWN

STEP 4

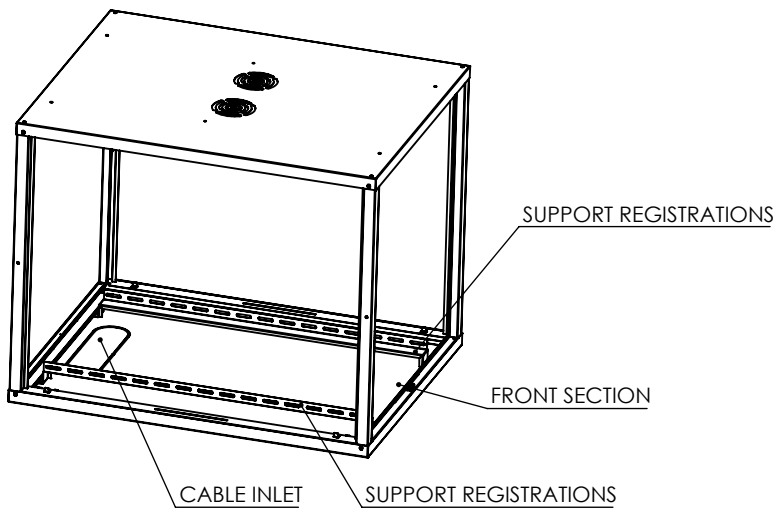

SCREW THE SUPPORT RECORDS TO THE FLOOR AS SHOWN AS SHOWN

STEP 5

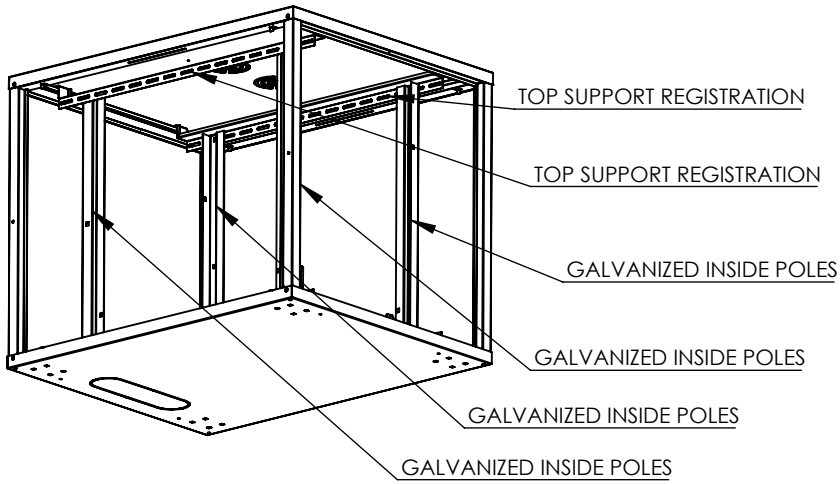

INSTALL UPPER SUPPORT RECORDS AND INTERNAL GALVANIZED POLES

STEP 6

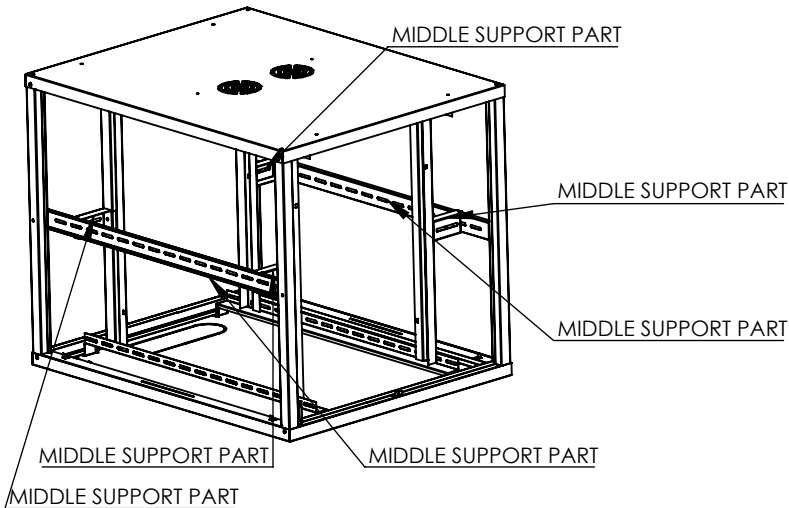

SCREW 19 INCH ADAPTER PIECES AND CENTER SUPPORT PIECES ACCORDING TO THE DIAGRAM

STEP 7

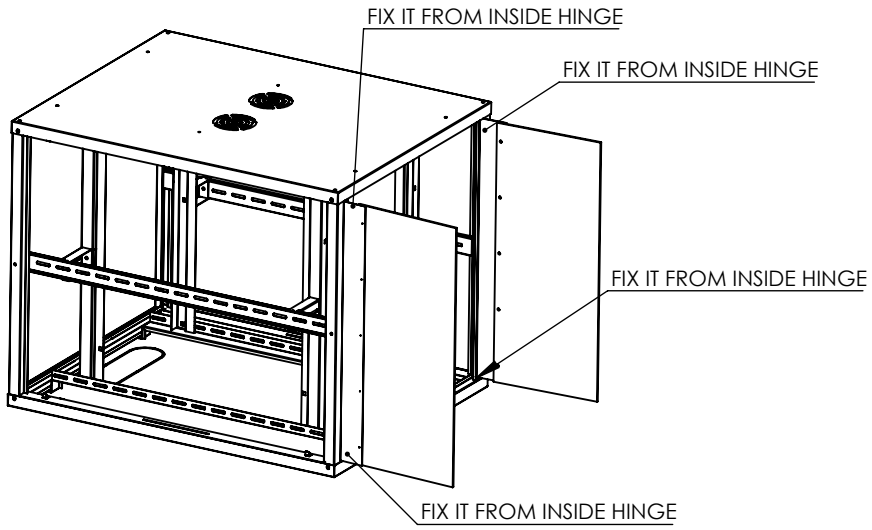

FIX THE FRONT DOORS AS SHOWN

STEP 8

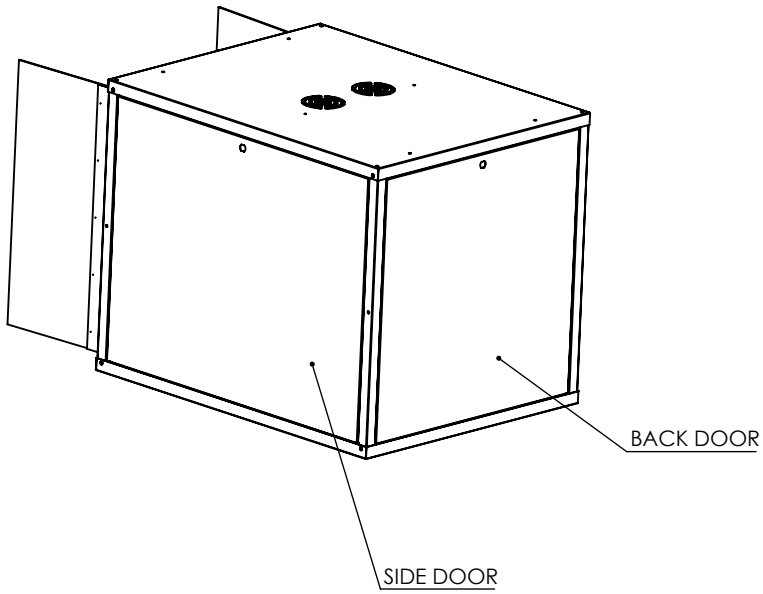

FIX THE SIDE AND REAR DOORS IN PLACE

THUS, THE INSTALLATION PROCESS IS COMPLETE